

ATTENZIONE: PER TENSIONI SPECIALI, SPECIFICARE SEMPRE IL MODELLO DI FORNO ED IL NUMERO DI MATRICOLA
ATTENTION: FOR SPECIAL VOLTAGES, PLEASE ALWAYS SPECIFY THE OVEN MODEL AND THE SERIAL NUMBER

ATTENTION: POUR TENSIONS SPÉCIALES, MERCI DE SPÉCIFIER TOUJOURS LE MODÈLE DU FOUR ET LE NUMÉRO DE SÉRIE
ACHTUNG: BEI SONDRSPANNUNGEN, BITTE IMMER OFEN-MODELL UND SERIENNUMMER GEBEN.

ed. 0614

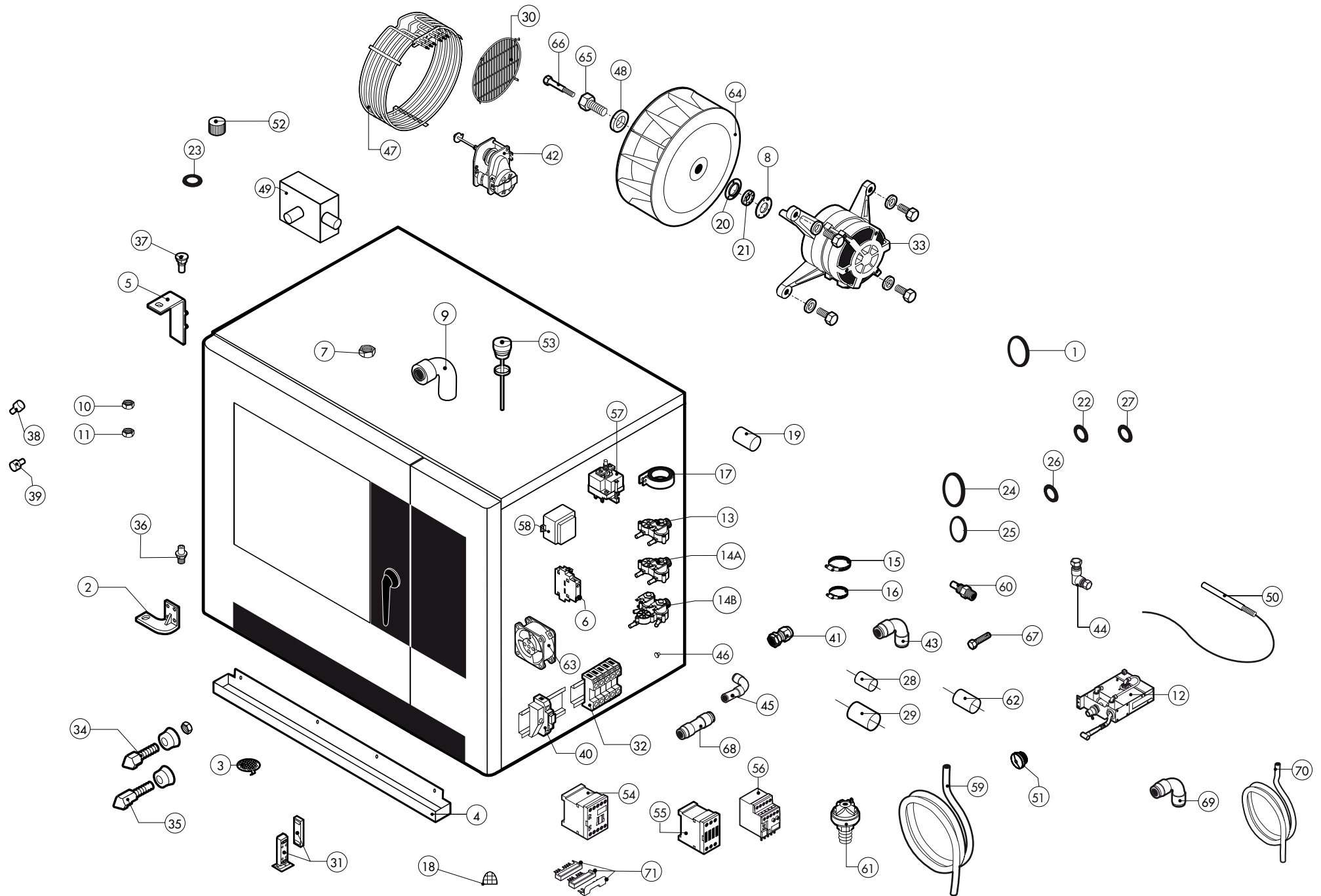

POS.	COD.	Pz.	DESCRIZIONE	DESCRIPTION	DESCRIPTION	BESCHREIBUNG	DESCRIPCIÓN
1	R70010370	2	ANELLO V-SEAL VA-0050 NBR	RING V-SEAL VA-0050 NBR	ANNEAU V-SEAL VA-0050 NBR	RING V-SEAL VA-0050 NBR	ANILLO V-SEAL VA-0050 NBR
2	R11207240	1	ASS.CERNIERA INF. M-V/061-101-102 2005	LOWER DOOR HINGE	CHARNIERE INFERIEURE PORTE	UNTERES SCHARNIER	BISAGRA INFERIOR
3	R10201710	1	ASS. FILTRO DI SCARICO D.86/44.5 M/210-12	DRAIN FILTER	FILTRE ENCEINTE	ABFLUSSFILTER	FILTRO DESAGUE
4	R69180240	1	BACINELLA SCARICO N/S072-102 2014	DRIP TRAY	PLATEAU D'ÉGOUTTEMENT	WASSERTROPFTASSE	BANDEJA DEL GOTEO
5	R14402130	1	CERNIERA SUPERIORE PORTA N/S 2014	UPPER DOOR HINGE	CHARNIERE SUPERIEURE PORTE	OBERES SCHARNIER	BISAGRA SUPERIOR
6	R65140430	1	CONT.AUS. 1L+1R 3RH1921-1EA11 SIEMENS	AUX.CONTACT 1L+1R	CONTACT AUXILIAIRE 1L+1R	ZUSÄTZLICHER KONTAKT 1L+1R	CONTACTO AUXILIAR 1L+1R
7	R65240040	1	CONTRODADO PER RACCORDO 107 Z/29	CABLE GLAND LOCK NUT	CONTRE-ECROU POUR RONDELLE FIXATION	MUTTER	CONTRODADO PASACABLE
8	R58003850	1	CONTROFLANGIA GUARN. GRANDE	MOTOR GASKET BRASS COUNTER FLANGE	CONTRE- BRIDE JOINT MOTEUR	GEGENFLANSCH F. MOTORDICHTUNG	CONTRABRIDA JUNTA MOTOR
9	R62280038	1	CURVA C/MORSET.HTS-HTSW X TUBO D.50 D.50X	CURVE WITH TERMINAL	COURBE AVEC BORNIER	KURVE MIT KLEMM	CURVA CON REGLETERA
10	R58004050	1	DADO PER PERNO CERNIERA REG. M/106-220	NUT FOR UPPER DOOR HINGE	ECROU CHEVILLE CHARNIERE SUPERIEURE	MUTTER F. OBERES SCHARNIERSTIFT	TUERCA PARA PERNO BISAGRA SUPERIOR
11	R58000360	1	DADO PER PERNO CERNIERA REG. N/S 2014	NUT FOR UPPER DOOR HINGE	ECROU CHEVILLE CHARNIERE SUPERIEURE	MUTTER F. OBERES SCHARNIERSTIFT	TUERCA PARA PERNO BISAGRA SUPERIOR
12	R62200172	1	DOCCIONE AV. N071/101/072/102 2014	SHOWER KIT	KIT DOUCHETTE	HANDBRAUSESATZ	KIT DUCHA
13	R65110230	1	E.V. 2 VIE 1P+1D 220V/50HZ J. G. CON ATTACC FINO ALLA SETTIMANA 10/2015	SOLENOID VALVE 2 VIE 220V 50HZ UNTIL WEEK 10/2015	ELECTROVANNE 2 VIE 220V 50HZ ÉLIMINÉ DU SEMAINE 10/2015	MAGNETVENTIL 2 VIE 220V 50HZ BIS WOCHE 10/2015	ELECTROVALVULA 2 VIE 220V 50HZ ELIMINATO DEL SEMANA 10/2015
13	R65110340	1	E.V. 2VIE 1PD+1D 230V 50/60HZ OUT J.G. D.10 DALLA SETTIMANA 10/2015	SOLENOID VALVE 1PD+1D 230V 50/60HZ OUT J.G. D.10 SINCE WEEK 10/2015	ELECTROVANNE 1PD+1D 230V 50/60HZ OUT J.G. D.10 DU SEMAINE 10/2015	MAGNETVENTIL 1PD+1D 230V 50/60HZ OUT J.G. D.10 VOM WOCHE 10/2015	ELECTROVALVULA 1PD+1D 230V 50/60HZ OUT J.G. D.10 DEL SEMANA 10/2015
14A*	R65110230	1	E.V. 2 VIE 1P+1D 220V/50HZ J. G. CON ATTACC FINO ALLA SETTIMANA 10/2015	SOLENOID VALVE 2 VIE 220V 50HZ UNTIL WEEK 10/2015	ELECTROVANNE 2 VIE 220V 50HZ ÉLIMINÉ DU SEMAINE 10/2015	MAGNETVENTIL 2 VIE 220V 50HZ BIS WOCHE 10/2015	ELECTROVALVULA 2 VIE 220V 50HZ ELIMINATO DEL SEMANA 10/2015
14A*	R65110340	1	E.V. 2VIE 1PD+1D 230V 50/60HZ OUT J.G. D.10 DALLA SETTIMANA 10/2015	SOLENOID VALVE 1PD+1D 230V 50/60HZ OUT J.G. D.10 SINCE WEEK 10/2015	ELECTROVANNE 1PD+1D 230V 50/60HZ OUT J.G. D.10 DU SEMAINE 10/2015	MAGNETVENTIL 1PD+1D 230V 50/60HZ OUT J.G. D.10 VOM WOCHE 10/2015	ELECTROVALVULA 1PD+1D 230V 50/60HZ OUT J.G. D.10 DEL SEMANA 10/2015
14B**	R65110240	1	E.V. 3 VIE 2P+1D 220V/50HZ J.G. CON ATTACC FINO ALLA SETTIMANA 10/2015	SOLENOID VALVE 3 VIE 220V 50HZ UNTIL WEEK 10/2015	ELECTROVANNE 3 VIE 220V 50HZ ÉLIMINÉ DU SEMAINE 10/2015	MAGNETVENTIL 3 VIE 220V 50HZ BIS WOCHE 10/2015	ELECTROVALVULA 3 VIE 220V 50HZ ELIMINATO DEL SEMANA 10/2015
14B**	R65110360	1	E.V. 3 VIE 2P+1D 230V 50/60HZ OUT J.G. D10 DALLA SETTIMANA 10/2015	SOLENOID VALVE 3VIE 2P+1D 230V 50/60HZ OUT J.G. D10 SINCE WEEK 10/2015	ELECTROVANNE 3VIE 2P+1D 230V 50/60HZ OUT J.G. D10 DU SEMAINE 10/2015	MAGNETVENTIL 3VIE 2P+1D 230V 50/60HZ OUT J.G. D10 VOM WOCHE 10/2015	ELECTROVALVULA 3VIE 2P+1D 230V 50/60HZ OUT J.G. D10 DEL SEMANA 10/2015
15	R61630031	4	FASCETTE ZINC.40-60/9	METAL CLAMPS 40-60/9	COLLIER DE SERRAGE 40-60/9	VERZINKTE SCHELLEN 40-60/9	ABRAZADERA 40-60/9
16	R61630011	2	FASCETTE ZINC.12-22/9	METAL CLAMPS	COLLIER DE SERRAGE	VERZINKTE SCHELLEN	ABRAZADERA
17	R65280490	1	FERRITE TOROIDALE FT36	FERRITE FT36	FERRITE FT36	FERRIT FT36	FERRITA FT36
18	R69180250	1	FILTRO SCARICO BACINELLA	SUPPRESSOR	FILTRE	FILTER	FILTRO
19	R65280200	3	FILTRO Cx=0,47µF Cy=2X10nF	INTERFERENCE SUPPRESSOR	FILTRE ANTIPARASITES	STOERSCHUTZFILTER	FILTRO
20	R58003840	1	FLANGIA GUARN. GRANDE	MOTOR GASKET BRASS FLANGE	BRIDE JOINT MOTEUR	FLANSCH F. MOTORDICHTUNG	BRIDA JUNTA MOTOR
21	R70020050	1	GUARNIZIONE MARK IV MLA 2400.02.05	GASKETS	JOINT	RINGDICHTUNG	JUNTA
22	R70010030	1	GUARNIZIONE OR 6,07 X 1,78 SILICONE	GASKETS	JOINT	RINGDICHTUNG	JUNTA
23	R70050150	1	GUARNIZIONE X TAPPO 2" PLAST.G40005	GASKETS	JOINT	RINGDICHTUNG	JUNTA
24	R70010120	1	GUARNIZIONE SILICONE ROSSO 90x90x3	RED GASKETS 90x90x3	JOINT ROUGE 90x90x3	ROTEN DICHTUNG 90x90x3	JUNTA ROJA 90x90x3
25	R70010150	1	GUARNIZIONE SILICONE ROSSO 55x35x3	RED GASKETS 55x35x3	JOINT ROUGE 55x35x3	ROTEN DICHTUNG 55x35x3	JUNTA ROJA 55x35x3
26	R70010210	1	GUARNIZIONE OR NBR 70 18,72x2,62 C.3075	GASKET OR 18,72x2,62	JOINT OR 18,72x2,62	RINGDICHTUNG OR 18,72x2,62	JUNTA OR 18,72x2,62
27	R70010050	1	GUARNIZIONE OR 7,60 X 2,62 OR 3030 NB	GASKET OR 7,60 X 2,62	JOINT OR 7,60 X 2,62	RINGDICHTUNG OR 7,60 X 2,62	JUNTA OR 7,60 X 2,62
28	R70060080	1	MANICOTTO SILICONE D.13X18X80	SILICON SLEEVE	SILICONE SLEEVE	SILIKONHÜLLE	FUNDA DE SILICONA
29	R70060050	3	MANICOTTO SILICONE D. 60	SILICON SLEEVE	SILICONE SLEEVE	SILIKONHÜLLE	FUNDA DE SILICONA
30	R75300070	1	MASCHERINA VENTILATORE D.350 N/S101 2014	FAN GUARD GRID D.350	GRILLE VENTILATEUR D.350	VENTILATORSCHUTZGITTER D.350	REJILLA VENTILADOR D.350
31	R65265100	1	MICRO PORTA MAGNETICO COMPLETO	DOOR SWITCH	MICRO PORTE	TUERSCHALTER	MICRO PUERTA
32	R65220290	1	MORSETTIERA LX1(TIPO 3)NEW C/TERRA PASS.	TERMINAL BOARD	BORNIER	KLEMMLEISTE	REGLETERA

A* - forni senza sistema di lavaggio, oven without washing system, four sans systèmes de lavage, Dämpfer ohne Reinigungssysteme, hornos sin sistema de lavado

B** - forni con sistema di lavaggio, oven with washing system, four avec systèmes de lavage, Dämpfer mit Reinigungssysteme, hornos con sistema de lavado

ATTENZIONE: PER ORDINARE I RICAMBI, SPECIFICARE SEMPRE IL MODELLO DI FORNO ED IL NUMERO DI MATRICOLA
ATTENTION: WHEN ORDERING SPARE PARTS, PLEASE ALWAYS SPECIFY THE OVEN MODEL AND THE SERIAL NUMBER

ATTENTION: POUR COMMANDER DES PIÈCES, MERCI DE SPECIFIER TOUJOURS LE MODÈLE DU FOUR ET LE NUMÉRO DE SÉRIE
ACHTUNG: UM ERSATZTEILE ZU BESTELLEN, BITTE IMMER OFEN-MODELL UND SERIENNUMMER GEBEN.

ed. 0614

POS.	COD.	Pz.	DESCRIZIONE	DESCRIPTION	DESCRIPTION	BESCHREIBUNG	DESCRIPCIÓN
33	R65040530	1	MOTORE KW 055 F3 4P 3039 200-440V I	MOTOR	MOTEUR	MOTOR	MOTOR
34	R69010260	1	NASELLO 1 STEP 6303-020022	DOOR LATCH 1 STEP	GACHE DE PORTE POUR OUVERTURE SIMPLE	SCHLISSNASE 1 STUFE	NARIZ 1 CIERRE
35	R69010270	1	NASELLO 2 STEP 6303-020030	DOOR LATCH 2 STEP	GACHE DE PORTE POUR OUVERTURE	SCHLISSNASE 2 STUFE	NARIZ 2 CIERRE
36	R58002670	1	PERNO INF.CERNIERA REG.C/FERMI SR.2005	LOWER HINGE PIN	CHEVILLE CHARNIERE INFERIEURE	UNTERES SIE SCHARNIERSTIFT	PERNO INFERIOR BISAGRA
37	R58000370	1	PERNO SUP.CERNIERA REG. N/S 2014	UPPER HINGE PIN	CHEVILLE CHARNIERE SUPERIEURE	OBERES SIE SCHARNIERSTIFT	PERNO SUPERIOR BISAGRA
38	R58003140	2	PERNO AGGANCIO DEFLETTORE	FAN GUARD PANEL PIN	PIVOT DEFLECTEUR	BOLZEN FÜR LUFTLEITBLECH	PERNO CIERRE DEFLECTOR
39	R58003110	2	PERNO FISSAGGIO DEFLETTORE	FAN GUARD PANEL PIN	PIVOT DEFLECTEUR	BOLZEN FÜR LUFTLEITBLECH	PERNO CIERRE DEFLECTOR
40	R65210020	3	PORTAFUSIBILE BARRA DIN 5x20	FUSE CARRIER	PORTE-FUSIBLE	SICHERUNGSHALTER	PORTAFUSIBILE
41	R65240030	1	PRESSACAVO PG 107 Z/29 (RACCORDO)	FAIRLEAD	PRESSE CABLE	ZUGENTLASTUNG	PRENSACABLES
42	R65090220	1	PROGRAMMAT. 1 CAMME V220/50HZ 1 CIRCUITO	DAMPER SYSTEM	SORTIE EVAPORATION MOUFLE	DAMPFABLASS-STELLMOTOR	MOTOR RESPIRADERO COMPLETO
43	R62090478	4	RACC. INTERMEDIO A GOMITO D.10 PM0310E	ELBOW PIPE FITTING	COURBE AVEC QUEUE	STUCK MIT SCHAFT	RACOR CON CODO
44	R62090633	1	RACCORDO OTTONE CURVO 10/10 C/OGIVA	ELBOW PIPE FITTING BRASS D.10	RACCORDEMENT A COUDE LAITON D 10	WINKELSTUTZEN AUS MESSING D,10	RACOR LATON DE GOMA D.10
45	R62090528	1	RACC.A GOMITO C/CODOLO 10x10 PM221010E	ELBOW PIPE FITTING (WITH TANG) 10x10	COURBE AVEC QUEUE 10x10	WINKELVERBINDUNGSSTUCK 10x10 MIT SCHAFT	RACOR DE GOMA CON CODO 10x10
46	R65110510	1	REGOL. PORTATA ROSSO ALPHATECH. 15LT/H	1.5 LT/H WATER FLOW REDUCER	REGULATUER DE DEBIT 1.5 LT.	DURCHFLUSSMONDERER 1.5 L/STD.	REGULADOR DE CAUDAL 1.5 LT.
47	R65011390	1	RESISTENZA CIRC.18000W 230V CAMERA 072	CHAMBER HEATING ELEMENT 18000W 230V	RESISTANCE MOUFLE 18000W 230V	GARRAUM HEIZKOERPER 18000W 230V	RESISTENCIA CAMARA 18000W 230V
48	R58004010	1	ROND.FISS.VENTOLA D 30/12.5	FAN WASHER Ø 30/12.5	RONDELLE TURBINE Ø 30/12.5	UNTERLEGSCHLEIBE Ø 30/12.5	ARANDELA FIJACION TURBINA Ø 30/12.5
49	R69180110	1	SCATOLA COND. SCARICO H/MV 102	QUENCHING-DRAIN COLLECTOR	BOITE DE CONDENSATION DECHARGE	KONDENSATION-ABFLUSS SCHACHTEL	CAJON CONDENSACION-DESAGÜE
50	R65320220	2	SONDA "K" 6X80 1,5 ML. TESTA RASTREM. 20 mm	PROBE "K" 6X80 1,5ML.	SONDE "K" 6X80 1,5ML.	FUEHLER "K" 6X80 1,5ML.	SONDA "K" 6X80 1,5ML.
51	R65321370	1	TAPPO ASSENZA CONNETTORE S/C SA 2014	COVER	BOUCHON	ABDECKUNG	TAPON
52	R69150100	1	TAPPO FEMMINA G 2" PP+25%FV NERO	COVER	BOUCHON	ABDECKUNG	TAPON
53	R58006690	1	TAPPO SFIATO COMPLETO SERIE 2014	COVER	BOUCHON	ABDECKUNG	TAPON
54	R65140380	2	TELERUTTORE 3RT1016-1AP02	CONTACTOR	CONTACTEUR	SCHUETZ	CONTACTOR
55	R65140400	3	TELERUTTORE 3RT1025-1AL20 SIEMENS	CONTACTOR	CONTACTEUR	SCHUETZ	CONTACTOR
56	R65160620	1	TERM. MOT. 3RU1116-1BB0 1,4-2,0 SIEMENS	THERMIC PROTECTION 3RU1116-1BB0 1,4-2,0	PROTECTION THERMIQUE 3RU1116-1BB0 1,4-2,0	MOTORSCHUTZSCHALTER 3RU1116-1BB0 1,4-2,0	TERMICO 3RU1116-1BB0 1,4-2,0
57	R65070350	1	TERMOSTATO SICUR. 360°C -25K 55.32572.8	THERMOSTAT	THERMOSTAT	THERMOSTAT	TERMOSTATO
58	R65180420	2	TRASF.RE 20VA 0-220-240/12V MOD.163.16	TRANSFORMER 20VA	TRANSFORMATEUR 20VA	TRANSFORMATOR 20VA	TRANSFORMADOR 20VA
59	R80150000	2	TUBO PE 10mm x 7 AZZURRO PM950612E	BLUE PIPE	TUBE	LEITUNG	TUBO AZUL
60	R58006160	2	UGELLO COND. D.0,8 CODOLO CIL.10	NOZZLE	BEC	DÜSE	BOQUILLA
61	R63070050	1	PRESSOSTATO 1/8" 0,5-0,35 BAR PH/91140	WATER SAFETY PRESSURE SWITCH	INT.A PRESSION SEC.-EAU	WASSER-DRUCKWACHTER	PRESOSTATO AQUA
62	R62030113	1	MANICOTTO RIDUZ. FF 1/8-1/4 OTTONE	REDUCTION COUPLING	MANCHON REDUCTION	REDUZIERMUFFE	MANGUITO REDUCCION
63	R65060050	2	VENTILATORE COMPATTO D.120 4715MS 23T	COMPONENTS VENTILATION MOTOR D.120	MOTEUR DE REFRROIDISSEMENT D.120	ABKÜHLUNGS MOTOR D.120	MOTOR DE ENFRIAMIENTO D.120
64	R75400440	1	VENTOLA D.350X114/12 50HZ P.D.	FAN	TURBINE	LUEFTERRAD	PALA VENTILADOR
65	R58004000	1	VITE FISS.VENTOLA M/12X1.5 SX	FAN SCREW M12x1.5 SX	VIS DE BLOCAGE TURBINE M12x1.5 SX	VENTILATORSCHRAUBE M12x1.5 SX	TORNILLO FIJACION TURBINA M12x1.5 SX
66	R61020562	1	VITE TE A2 M 6X55 UNI 5737.	MOTOR SCREW TE A2 M6x55	VIS DE BLOCAGE MOTEUR TE A2 M6x55	MOTORSCHRAUBE TE A2 M6x55	TORNILLO MOTOR TE A2 M6x55
67	R61260152	2	VITE TCB+A2 M 4X10	SCREW TCB+A2 M 4X10	VIS TCB+A2 M 4X10	SCHRAUBE TCB+A2 M 4X10	TORNILLO TCB+A2 M 4X10
68	R62090458	1	RACC. INTERMEDIO DIRITTO D.10 PM0410E	PIPE FITTING	COURBE	STUCK	RACOR
69	R62090918	1	RACC. INT. A GOMITO D.10 SPEEDFIT PEM0310W DALLA SETTIMANA 28/2014 (07.07.2014)	WHITE ELBOW PIPE FITTING D.10 FROM WEEK 28/2014 (07.07.2014)	COURBE AVEC QUEUE DU SEMAINE 28/2014 (07.07.2014)	STUCK MIT SCHAFT VOM WOCHEN 28/2014 (07.07.2014)	RACOR CON CODO DEL SEMANA 28/2014 (07.07.2014)
70	R80150060	0,65 m	TUBO PEX-B 10MM DALLA SETTIMANA 28/2014 (07.07.2014)	WHITE PIPE FROM WEEK 28/2014 (07.07.2014)	TUBE DU SEMAINE 28/2014 (07.07.2014)	LEITUNG VON WOCHEN 28/2014 (07.07.2014)	TUBO DEL SEMANA 28/2014 (07.07.2014)
71	R65140370	1	KIT INVERSIONE X TELERUTT. 4KW SIEMENS	INVERSION KIT FOR CONTACTOR 4KW	KIT D'INVERSION POUR CONTACTEUR 4KW	KIT WENDEN SCHUETZ 4KW	KIT INVERSION CONTACTOR 4KW

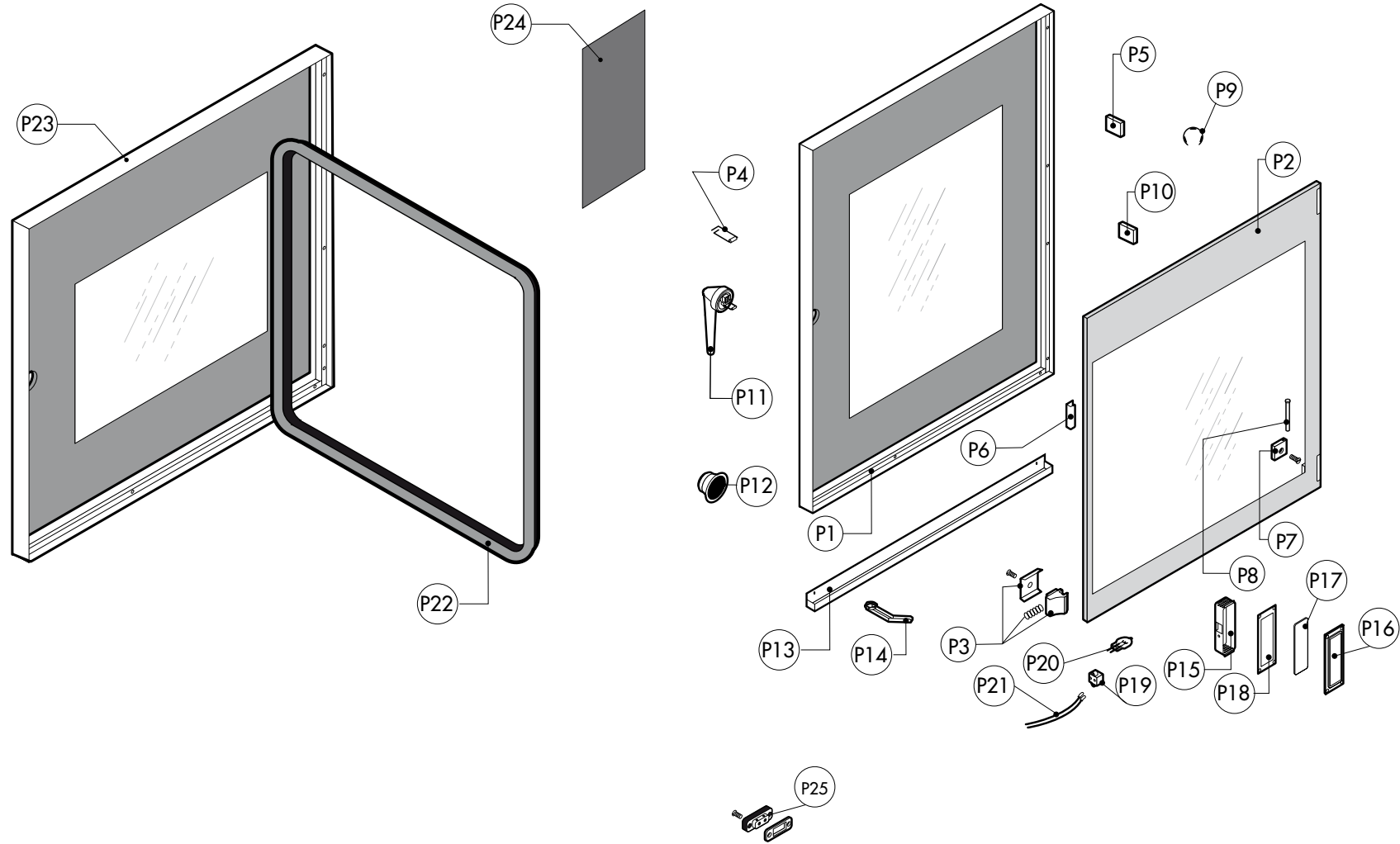

ATTENZIONE: PER TENSIONI SPECIALI, SPECIFICARE SEMPRE IL MODELLO DI FORNO ED IL NUMERO DI MATRICOLA
ATTENTION: FOR SPECIAL VOLTAGES, PLEASE ALWAYS SPECIFY THE OVEN MODEL AND THE SERIAL NUMBER

ATTENTION: POUR TENSIONS SPÉCIALES, MERCI DE SPÉCIFIER TOUJOURS LE MODÈLE DU FOUR ET LE NUMÉRO DE SÉRIE
ACHTUNG: BEI SONDRERSPANNUNGEN, BITTE IMMER OFEN-MODELL UND SERIENNUMMER GEBEN.

ed. 0614

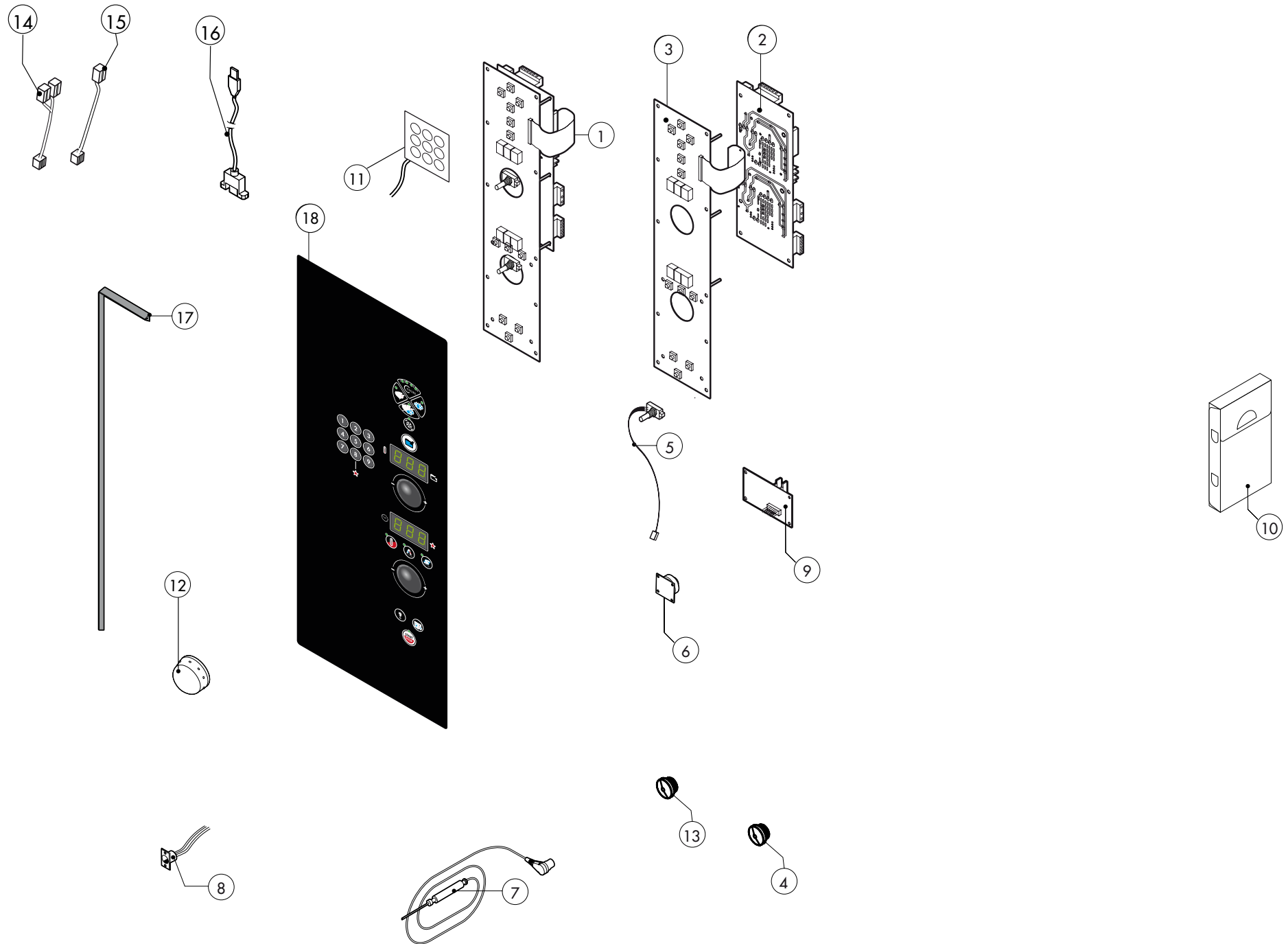

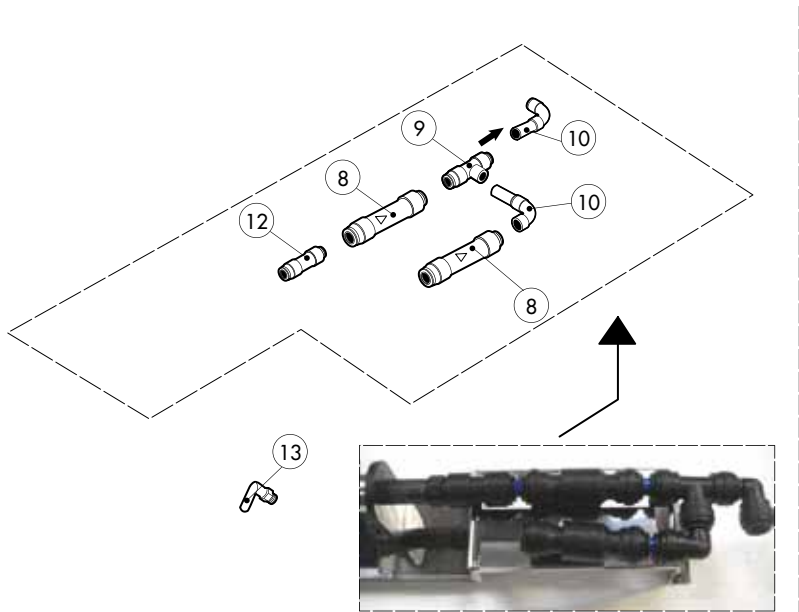

fino alla settimana 27/2014 - until week 27/2014
 élimine du semaine 27/2014
 bis woche 27/2014 - eliminato del semana 27/2014

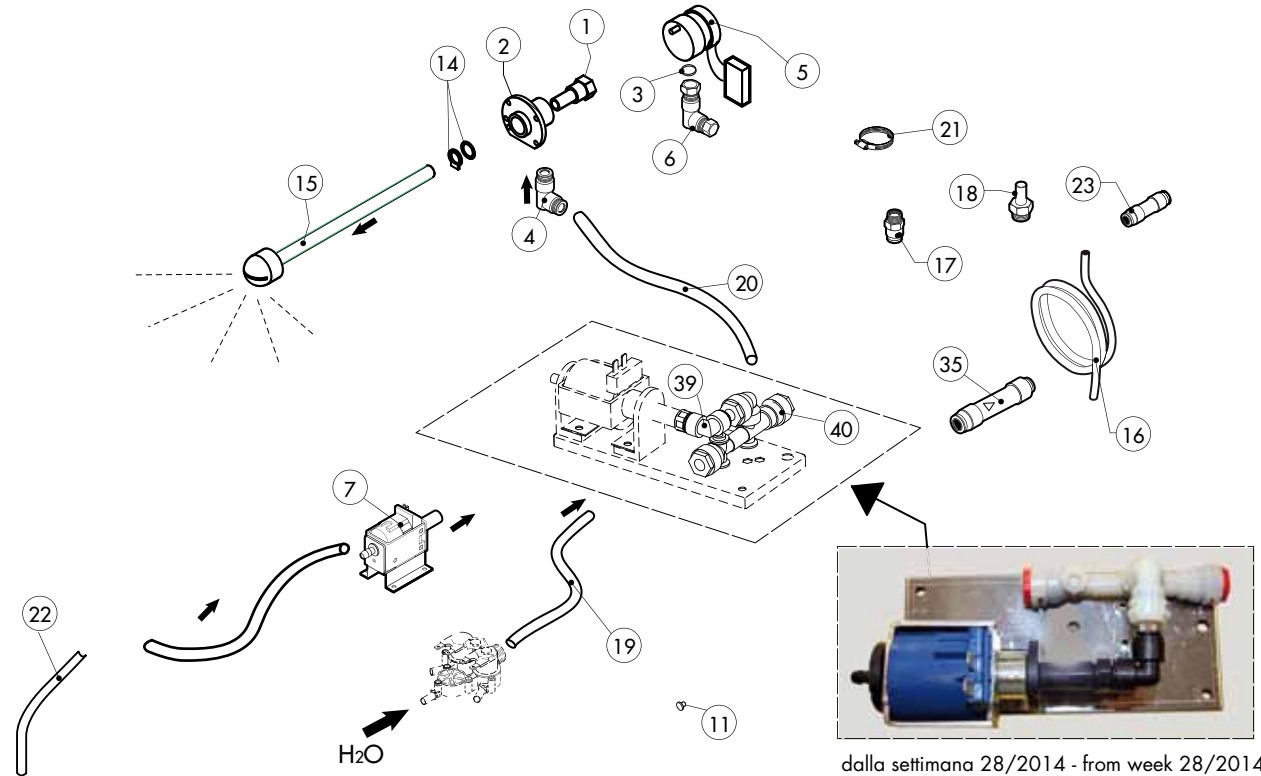

dalla settimana 28/2014 - from week 28/2014
 du semaine 28/2014 - vom woche 28/2014
 del semana 28/2014

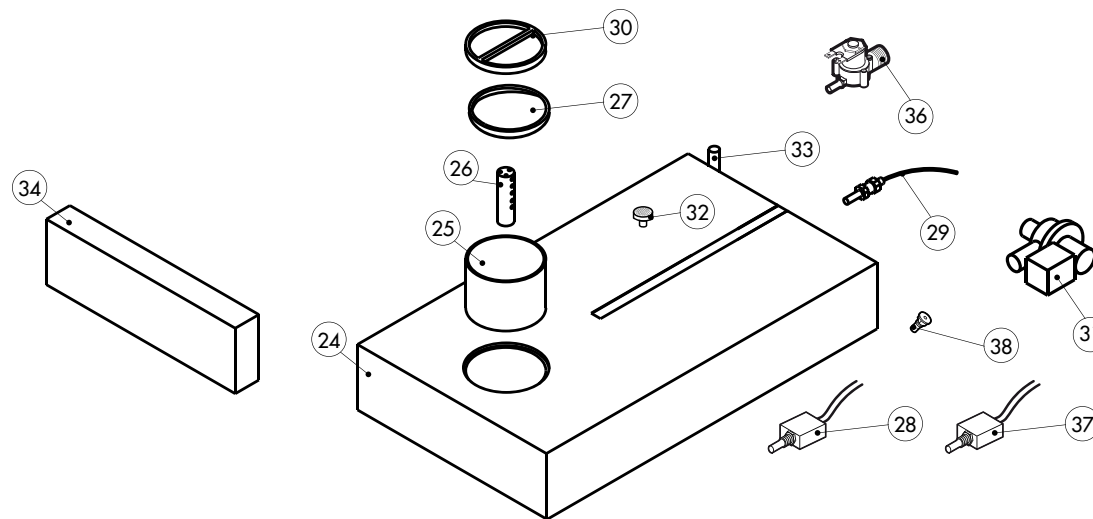

ATTENZIONE: PER ORDINARE I RICAMBI, SPECIFICARE SEMPRE IL MODELLO DI FORNO ED IL NUMERO DI MATRICOLA
ATTENTION: WHEN ORDERING SPARE PARTS, PLEASE ALWAYS SPECIFY THE OVEN MODEL AND THE SERIAL NUMBER

ATTENTION: POUR COMMANDER DES PIÉCES, MERCI DE SPECIFIER TOUJOURS LE MODELE DU FOUR ET LE NUMERO DE SERIE
ACHTUNG: UM ERSATZTEILE ZU BESTELLEN, BITTE IMMER OFEN-MODELL UND SERIENNUMMER GEBEN.

ed. 0614

POS.	COD.	Pz.	DESCRIZIONE	DESCRIPTION	DESCRIPTION	BESCHREIBUNG	DESCRIPCIÓN
1	R58007000	1	PERNO ROTANTE LAVAGGIO MOB	ROTATING PIVOT	PIVOT TOURNANT	UMLAUFENDE STÜTZE	GOZNE ROTATORIO
2	R58007020	1	FLANGIA LAVAGGIO MOB	WASHING SYSTEM FLANGE	BRIDE BRAS DE LAVAGE	FLANSCH WASCHARMBEFESTIGUNG	PLATINA LAVADO
3	R70010080	1	GUARNIZIONE OR 14x2 Viton DIN 981	GASKETS	JOINT	RINGDICHTUNG	JUNTA
4	R62090663	1	RACCORDO OTTONE NICH.A L C/OGIVA 10X1/4"	ELBOW PIPE FITTING BRASS D.10x1/4"	RACCORDEMENT A COUDE LAITON D 10x1/4"	ELBOW PIPE FITTING BRASS D.10x1/4"	RACOR LATON DE GOMA D.10x1/4"
5	R65090260	1	MOTORID. LAV. METEOR (58U59DB4A1-00)	WASHING GEARED MOTORS	MOTO-REDUCTEURS DE LAVAGE	GETRIEBEMOTOREN	MOTORREDUCTORES LAVADO
6	R62090633	1	RACCORDO OTTONE CURVO 10/10 C/OGIVA	ELBOW PIPE FITTING BRASS D.10	RACCORDEMENT A COUDE LAITON D 10	WINKELSTUTZEN AUS MESSING D,10	RACOR LATON DE GOMA D.10
7	R65110600	1	POMPA ELETTRIC. A PIS. OSC. ET508LAB 2273	POMPE DETERGEANT	DETRGENT PUMP	REINIGERPUMPE	BOMBA DETERGENTE
8	R65110680	2	VALVOLA ANTIRITORNO J.G. 10SCV Eliminato dalla settimana 27/2014 (4/7/2014)	ANTI-BACK FLOW UNTIL WEEK 27/2014 (4/7/2014)	ANTIRETOUR ÉLIMINÉ DU SEMAINE 27/2014 (4/7/2014)	RUCKFLUSSVERHINDERER BIS WOCHE 27/2014 (4/7/2014)	ANTIRETORNO ELIMINATO DEL SEMANA 27/2014 (04/07/2017)
9	R62090468	1	RACCORDO INTERMEDIO A "T" D.10 PM0210E Eliminato dalla settimana 27/2014 (4/7/2014)	T MIDLING PIPE FITTING D.10 UNTIL WEEK 27/2014 (4/7/2014)	RACCORD INTERMEDIAIRE A "T" D.10 ÉLIMINÉ DU SEMAINE 27/2014 (4/7/2014)	MITTELVERBINDUNGSSTUCK D.10 "T"- FORMIG BIS WOCHE 27/2014 (4/7/2014)	RACOR INTERMEDIO TIPO "T" D.10 ELIMINATO DEL SEMANA 27/2014 (04/07/2017)
10	R62090528	1	RACC.A GOMITO C/COD. 10x10 PM221010E Eliminato dalla settimana 27/2014 (4/7/2014)	ELBOW PIPE FITTING (WITH TANG) 10x10 UNTIL WEEK 27/2014 (4/7/2014)	COURBE AVEC QUEUE 10x10 ÉLIMINÉ DU SEMAINE 27/2014 (4/7/2014)	WINKELVERBINDUNGSSTUCK 10x10 MIT SCHAFT BIS WOCHE 27/2014 (4/7/2014)	RACOR DE GOMA CON CODO 10x10 ELIMINATO DEL SEMANA 27/2014 (04/07/2017)
11	R65110530	1	REGOL. PORTATA VIOLA 2LT/1'	2 LT/1' WATER FLOW REDUCER	REGULATUER DE DEBIT 2 LT/1'	DURCHFLUSSMONDERER 2 LT/1'	REGULADOR DE CAUDAL 2 LT/1'
12	R62090618	1	RIDUZIONE INTERMEDIA 10-8 PM201008E Eliminato dalla settimana 27/2014 (4/7/2014)	REDUCTION PIPE FITTING UNTIL WEEK 27/2014 (4/7/2014)	RACCORD DROIT REDUCTION ÉLIMINÉ DU SEMAINE 27/2014 (4/7/2014)	GERADE ANSCHLUSS-VERKLEINERUNG BIS WOCHE 27/2014 (4/7/2014)	RACOR DERECHO REDUCCION ELIMINATO DEL SEMANA 27/2014 (04/07/2017)
13	R62090678	1	RACC.A GOMITO C/CODOLO 8X8 PM220808E Eliminato dalla settimana 27/2014 (4/7/2014)	ELBOW PIPE FITTING (WITH TANG) 8X8 UNTIL WEEK 27/2014 (4/7/2014)	COURBE AVEC QUEUE 8x8 ÉLIMINÉ DU SEMAINE 27/2014 (4/7/2014)	WINKELVERBINDUNGSSTUCK 8X8 MIT SCHAFT BIS WOCHE 27/2014 (4/7/2014)	RACOR DE GOMA CON CODO 8x8 ELIMINATO DEL SEMANA 27/2014 (04/07/2017)
14	R70045120	1	KIT GUARNIZIONI X LAVAGGIO MOB	GASKETS KIT	ENSEMBLE JOINTS	DICHTUNGSSATZ	KIT JUNTAS
15	R58007040	1	TESTA LAVAGGIO MOB+ALBERO L=120 (071/T06)	WASHING SYSTEM INNER ASSEMBLY	ENSEMBLE INTERIEUR DU LAVAGE	INNEN WASCHARMBEFESTIGUNG	KIT INTERNO LAVADO
16	R70070080	1m	TUBO CARICO ACQUA D.23mm x13	PIPE	TUBE	LEITUNG	TUBO
17	R62090508	1	RACC.TERMIN.DIR.FIL.CON.10X1/4 PM011002E	STRAIGHT THREADED TERMINAL PIPE FITTING	RACCORDEMENT	ENDVERBINDUNGSSTUCK GESCHNITTEN	RACOR
18	R62090518	1	RACC.TERMIN.C/COD.F.CON.10X1/4 PM051002E	TERMINAL PIPE FITTING (WITH TANG)	RACCORD AVEC QUEUE	ENDVERBINDUNGSSTUCK MIT SCHAFT	RACOR TERMINAL CON CODO
19	R80120060	1m	TUBO SILIC. TRASP. SR60/TR 7/12.	PIPE	TUBE	LEITUNG	TUBO
20	R80150000	1m	TUBO PE D.10mm x 7 AZZURRO	PE D.10 MM X7 WATER FLEXIBLE PIPE	TUBE FLEXIBLE EAU D. 10x7	WASSERFLEXROHRLEITUNG PE D.10mm x 7	TUBO FLEXIBLE AGUA PE D.10mm x 7
21	R61630121	2	FASCETTE ZINC.BIFILARE A MOLLA D.13,7mm	METAL CLAMPS	COLLIER DE SERRAGE	VERZINKTE SCHELLEN	ABRAZADERA
22	R80150020	1,5m	TUBO PU 8mm x 6 TRASPARENTE	PE D.8 MM X 6 DETERGENT FLEXIBLE PIPE	TUBE DETERGEANT D. 8x6	ROHRLEITUNG F. REINIGER PE D.8mm x 6	TUBO DETERGENTE PE D.8mm x 6
23	R62090878	1	RACC. INTERMEDIO DIRITTO D.8 PM0408E	PIPE FITTING	COURBE	STUCK	RACOR
24	R14162580	1	CASSETTO DETERGENTE COMPLETO	DETERGENT DRAWER	TIROIR DÉTERGENT	SCHUBFACH REINIGUNGSMITTEL	CAJÓN DETERGENTE
25	R69040060	1	FILTRO CASSETTO MISCELAZIONE N/S 2014	SUPPRESSOR DRAWER	FILTRE TIROIR	FILTER FACH	FILTRO CAJON
26	R69040050	1	SPRUZZATORE CASSET. MISCELAZIONE N/S 2014	SPRAY	PULVÉRISER	SPRAY	ROCIAR
27	R69040020	1	GHIERA D.90 CASS. MISCEL.DET. N/S 2014	FERRULE D.90	VIROLE D.90	ZWINGE D.90	CONTERA D.90
28	R65260900	1	MICRO CASSETTO MISCELAZIONE N/S 2014 DALLA SETTIMANA 26/2014 (23/06/2014)	DRAWER MICRO FROM WEEK 26/2014 (23/06/2014)	MICRO TIROIR DU SEMAINE 26/2014 (23/06/2014)	FACH-MICRO VOM WOCHE 26/2014 (23/06/2014)	MICRO CAJON DEL SEMANA 26/2014 (23/06/2014)
29	R65260910	2	CONTROLLO LIVELLO CASS. MISCEL. N/S 2014	LEVEL CONTROLLER DRAWER	CONTROLES DE NIVEAU TIROIR	KONTROLL FACH	CONTROLLOR DE NIVEL CAJON
30	R69040040	1	TAPPO D.90 CASS.MISCEL.DET. N/S 2014	COVER	BOUCHON	ABDECKUNG	TAPON
31	R65110300	1	POMPA SINCRONA 220V 50HZ 30W	POMPE	PUMP	PUMPE	POMPA
32	R62090718	1	FILTRINO D.5 SFIL00VT00	SUPPRESSOR	FILTRE	FILTER	FILTRO
33	R58006970	1	PERNO ø10 DIVIS.CASSETTI N/S 072-102 2014	PIN	PIVOT	BOLZEN	PERNO
34	R69040070	1	FINTO CASSETTO TELAIO N/S 2014	FAKE DRAWER FRAME	CADRE DE TIROIR FAUX	FAKE EINSCHUBBRAHMEN	MARCO DE EL CAJÓN FALSO
35	R65110690	1	RACCORDO 3/4F+JG10 C/ANTIRIT. E2120202	PIPE FITTING	COURBE	STUCK	RACOR
36	R65110200	1	E.V. 1 VIA 220V 50HZ X J.G. CON ATTACC	SOLENOID VALVE 1 VIE 220V 50HZ	ELECTROVANNE 1 VIE 220V 50HZ	MAGNETVENTIL 1 VIE 220V 50HZ	ELECTROVALVULA 1 VIE 220V 50HZ
37	R65260900K	1	KIT MICROINT. CASSETTO MISC. N/S 2014 eliminato dalla settimana 25/2014 (20/06/2014)	KIT DRAWER MICRO UNTIL WEEK 25/2014 (20/06/2014)	KIT MICRO TIROIR ÉLIMINE DU SEMAINE 25/2014 (20/06/2014)	KIT FACH-MICRO BIS WOCHE 25/2014 (20/06/2014)	KIT MICRO CAJON ELIMINATO DEL SEMANA 25/2014 (20/06/2014)
38	R58006951	1	PERNO MICRO L=26 C/SEDE MOLLA CAS. DET. N/S DALLA SETTIMANA 26/2014 (23/06/2014)	PIN FROM WEEK 26/2014 (23/06/2014)	PIVOT DU SEMAINE 26/2014 (23/06/2014)	BOLZEN VOM WOCHE 26/2014 (23/06/2014)	PERNO DEL SEMANA 26/2014 (23/06/2014)
39	R62090498	1	RACC.INTERMEDIO A GOMITO D.8 PM0308E DALLA SETTIMANA 28/2014 (07/07/2014)	ELBOW PIPE FITTING FROM WEEK 28/2014 (07/07/2014)	COURBE AVEC QUEUE DU SEMAINE 28/2014 (07/07/2014)	WINKELVERBINDUNGSSTUCK VOM WOCHE 28/2014 (07/07/2014)	RACOR DE GOMA DEL SEMANA 28/2014 (07/07/2014)
40	R62090888	1	COLLET.RES.ACET. 3VIE- 2D.10+1D.8 + 2ANTIRIT DALLA SETTIMANA 28/2014 (07/07/2014)	MANIFOLD FROM WEEK 28/2014 (07/07/2014)	COLLECTEUR DU SEMAINE 28/2014 (07/07/2014)	KRÜMMER VOM WOCHE 28/2014 (07/07/2014)	COLECTOR DEL SEMANA 28/2014 (07/07/2014)