

ATTENTION : Il existe 2 configurations au niveau de l'arbre de transmission et des joints d'étanchéité associés. Choisir parmi les repères 1 à 3 ou 5 à 8, selon la hauteur des **plats d'entraînement** de l'arbre de transmission sur votre machine.
 $h = 18,5 \text{ mm}$; $H = 25,5 \text{ mm}$

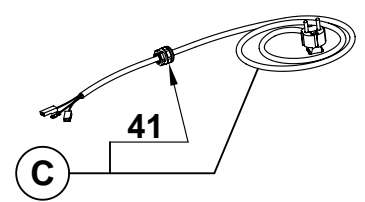

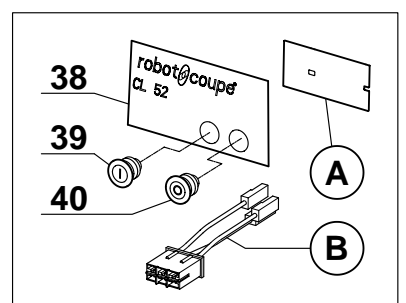

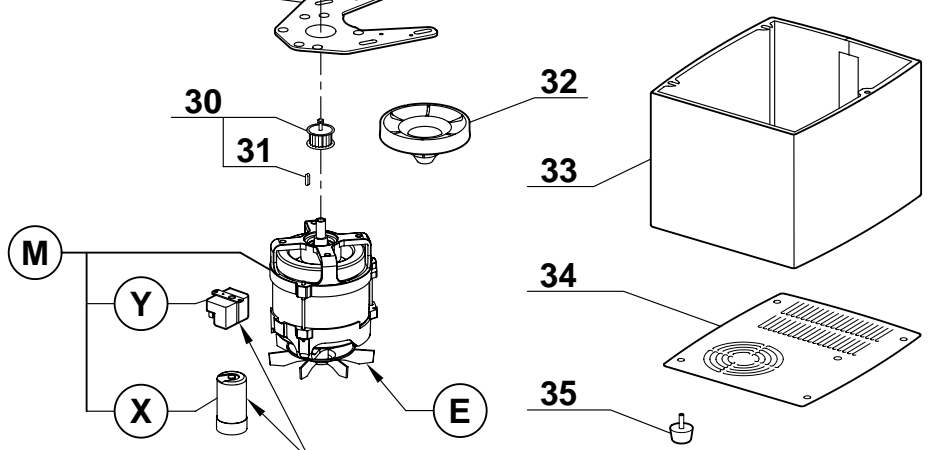

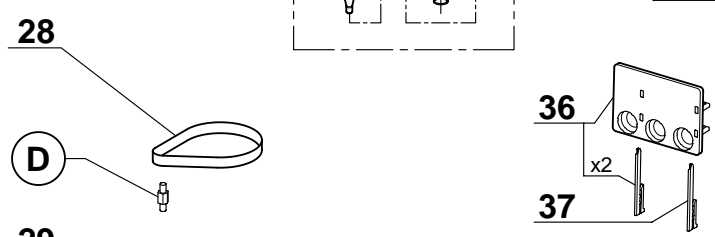
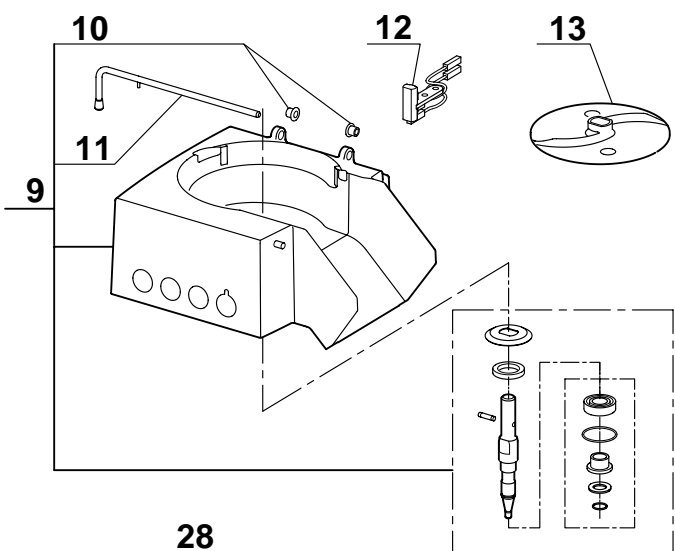
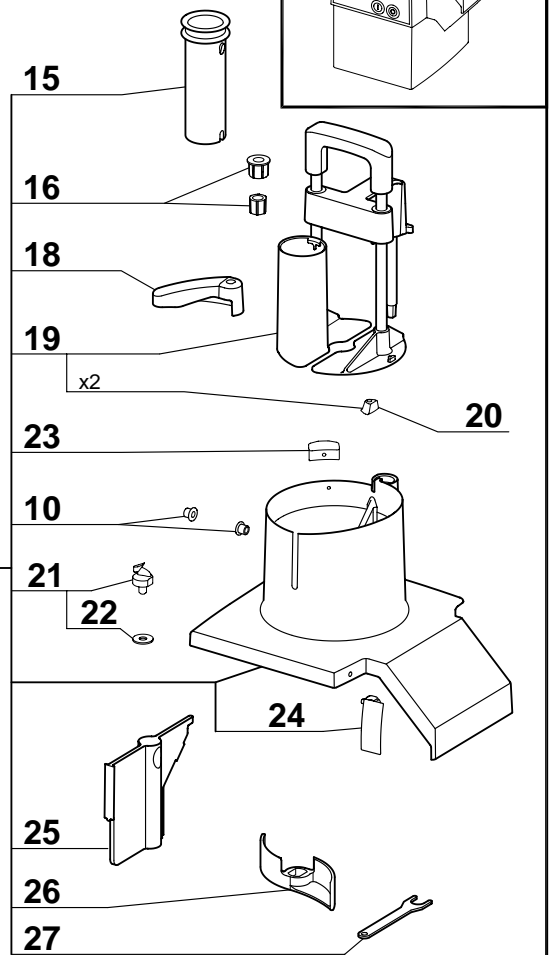
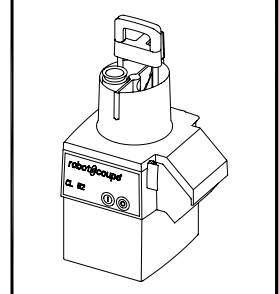
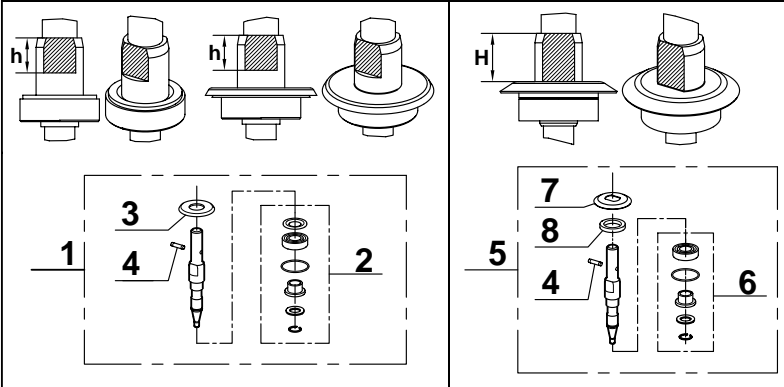



WARNING : There are 2 configurations regarding the transmission shaft and the associated seals. Choose among indexes 1 to 3 or 5 to 8, according to the height of the transmission shaft **driving flats** on your machine.



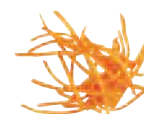
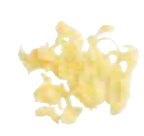

Uniquement pour moteur monophasé.
 Only for single phase motor.

Pos.	Part No	Beschreibung	Pos.	Part No	Beschreibung
A	102480	PLATINE CL50C MONOPH.			
B	29599	KABELSATZ CL50 D MONO			
C	507026	ANSCHLUSSKAB. EUR 6			
D	119145	CL55D SUPPORT BRACE			
E	104925	LUEFTER			
M	303086	CL55D MOTOR 220/60/1			
X	600018	KONDENSATOR 60MF 250/290V			
Y	503092	RELAIS 2CR3 209			
001	29693	ANTRIEBSWELLE KPL. (ALT) CL52D			
002	29630	KOMB. LAGER CL50D KPL			
003	39197	DICHTUNG KOMPLETT CL50D			
004	110308	MITNEHMERSTIFT			
005	39199	ANTRIEBSWELLE KPL. (NEU)			
006	39273	LAGER KOMPL. + DICHT. (NEU)			
007	101547	ABWEISER CL50D			
008	501678	DICHTUNGSRING 25X42X7			
009	39471	SCHUESSEL + ANTRIEBSWELLE			
010	29058	KUNSTSTOFFBCHSE			
011	100703	SCHARNIERSTIFT			
012	29451	REEDKONTAKT R301 B			
013	102690	AUSWURFSCHIEBE GRAU CL50D			
014	29694	DECKEL KOMPLETT CL52D			
015	118324	KAROTTEN STOPFER CL50D			
016	29691	KUNSTSTOFFBUCHSE (SATZ)			
018	29705	CL55 MAGNET CASE ASSEMBLY			
019	118428	STOPFER KOMPLETT			
020	29706	FUHRUNG FUR DRUCKER			
021	29692	KOHLSTRUNKBOHRER CL52D			
022	117200	UNTERLEGSCHIEBE FR SICHERUNGSMUTTER CL			
023	117321	ANTI-FRICTION STOP			
024	29501	VERSCHLUSSHAKEN			
025	118008	CL52D ABNEHMBARE WAND			
026	118420	AUSWERFER CL60D			
027	118436	SCHLUESSEL KOHLSTRUNKB.CL50D			
028	515482	RIEMEN CL401/CL50			
029	117689	CL50C MOTORHALTER.PLATTE			
030	29532	ANTRIEBSRITZEL MOTOR			
031	502768	SICHERUNGSRING 4X4X16			
032	117682	ANTRIEBSRAD CL 50C			
033	118430	EDELSTAHLGEHAEUSE CL52			
034	117687	RUCKWAND CL50C U			
035	500247	FUSS			
036	29533	PLATINENHALTERUNG KOMP			
037	117703	SICHERUNGSSTIFT TASTENPLA			
038	406516	FRONTPLATTE CL52			
039	502170	FLACHE TASTE GRUN			
040	502169	FLACHE TASTE ROT			
041	515515	KABELVERSCHRAUBUNG			



	R 201 / R 211 R 301 R 301 Ultra R 401 CL 20 / CL 25	R 402 R 402 V.V.	CL 30	DISCS	R 502/R 502 V.V. R 602/R 602 V.V. CL 50/CL 50 Ultra CL 52/CL 55/CL 60
SLICERS				Almonds 0,6 mm	28166
				0,8 mm	28069
	27051	27051		1 mm	28062
	27555	27555		2 mm	28063
	27086	27086		3 mm	28064
	27566	27566		4 mm	28004
	27087	27087		5 mm	28065
	27786	27786		6 mm	
				8 mm	28066
				10 mm	28067
				14 mm	28068
				4 mm for cooked potatoes	27244
				6 mm for cooked potatoes	27245
RIPPLE CUT SLICERS	27621	27621		2 mm	27068
				3 mm	27069
				5 mm	27070
GRATERS	27588	27588	27148	1,5 mm	28056
	27577	27577	27149	2 mm	28057
	27511	27511	27150	3 mm	28058
				4 mm	28073
				5 mm	28059
	27046	27046		6 mm	
				7 mm	28016
	27632	27632		9 mm	28060
	27764	27764		Parmesan	28061
	27191	27191		Röstis potatoes	27164
	27078	27078		0,7 mm for horseradish paste	
	27079	27079		1 mm for horseradish paste	28055
	27130	27130		1,3 mm for horseradish paste	
JULIENNE				1 x 8 mm	28172
				1 x 30 onions/Cabbage	28153
	27599	27599		2 x 2 mm	28051
	27080	27080		2 x 4 mm	27072
	27081	27081		2 x 6 mm	27066
				2 x 8 mm	27067
				2 x 10 mm	28173
				3 x 3 mm	28101
	27047	27047		4 x 4 mm	28052
	27610	27610		6 x 6 mm	28053
	27048	27048		8 x 8 mm	28054



	R 402 / R 402 V.V. CL 30	DISCS	R 502 / R 502 V.V. R 602 / R 602 V.V. CL 50 / CL 50 Ultra CL 52 / CL 55 / CL 60
DICING EQUIPMENTS  1 DICING GRID + 1 SLICER	■ 27113	5 x 5 x 5 mm	■ 28110
	■ 27114	8 x 8 x 8 mm	■ 28111
	■ 27298	10 x 10 x 10 mm	■ 28112
		12 x 12 x 12 mm	
		14 x 14 x 5 mm (mozzarella)	■ 28181
		14 x 14 x 10 mm	■ 28179
		14 x 14 x 14 mm	■ 28113
		20 x 20 x 20 mm	■ 28114
	25 x 25 x 25 mm	■ 28115	
	50 x 70 x 25 mm (salad)	■ 28180	
FRENCH FRIES EQUIPMENTS 	▲ 27116	8 x 8 mm	▲ 28134 (1)
	▲ 27117	10 x 10 mm	▲ 28135 (1)
		10 x 16 mm	▲ 28158 (1)

REMINDER



- Dicing equipment delivered with : 1 dicing grid + 1 slicing disc.
 - ▲ French Fries equipment delivered with : 1 French Fries disc + 1 slicing disc.
- (1) Not available for CL 55 and CL 60 with pusher feed head

ACCESSORIES

	REF.
POLYCARBONATE WALL DISCS HOLDER For discs R201 to R402 V.V. CL20 to CL30 	27019
POLYCARBONATE SET OF DISCS For R502 to R602 V.V. discs CL50 to CL60 V.V. 	27258
STAINLESS STEEL WALL DISCS HOLDER (receives 6 discs) 	101230
D-CLEAN KIT : CLEANING TOOL DICING GRIDS 	39881 NEW



The widest range of cuts

Slicers

CL 50 - CL 50 Ultra - CL 52 - CL 55 - CL 60 - R 502 - R 502 V.V. - R 602 - R 602 V.V.

Almonds 0,6 mm

Ref. : 28166

0,8 mm

Ref. : 28069

1 mm

Ref. : 28062

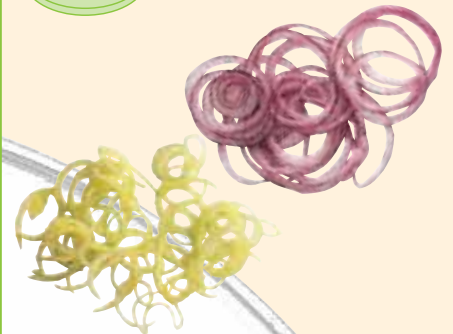
2 mm

Ref. : 28063

3 mm

Ref. : 28064

4 mm

Ref. : 28004

5 mm

Ref. : 28065

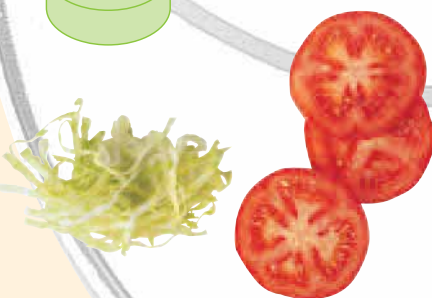
8 mm

Ref. : 28066

10 mm

Ref. : 28067

14 mm

Ref. : 28068

Cooked potatoes
4 mm

Ref. : 27244

Cooked potatoes
6 mm

Ref. : 27245











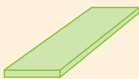













The widest range of cuts

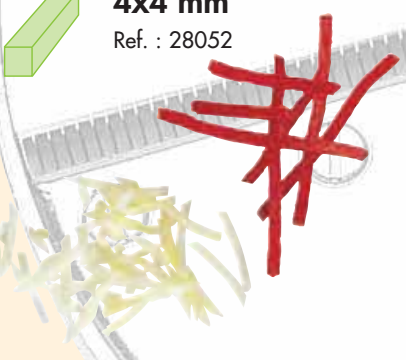





Julienne

CL 50 - CL 50 Ultra - CL 52 - CL 55 - CL 60 - R 502 - R 502 V.V. - R 602 - R 602 V.V.

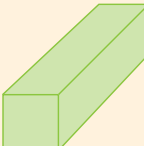
 <p>1 x 8 mm Ref. : 28172</p> 	 <p>1x26 mm Onions and cabbage Ref. : 28153</p> 	 <p>2x2 mm Ref. : 28051</p> 	 <p>2x4 mm Ref. : 27072</p> 
 <p>2x6 mm Ref. : 27066</p> 	 <p>2x8 mm Ref. : 27067</p> 	 <p>2x10 mm Ref. : 28173</p> 	 <p>3x3 mm Ref. : 28101</p> 
 <p>4x4 mm Ref. : 28052</p> 	 <p>6x6 mm Ref. : 28053</p> 	 <p>8x8 mm Ref. : 28054</p> 	

French Fries

CL 50 - CL 50 Ultra - CL 52 - CL 55 - CL 60 - R 502 - R 502 V.V. - R 602 - R 602 V.V.

 <p>8x8 mm Ref. : 28134</p> 	 <p>10x10 mm Ref. : 28135</p> 	 <p>10x16 mm Ref. : 28158</p> 
--	---	--

The widest range of cuts

Graters

CL 50 - CL 50 Ultra - CL 52 - CL 55 - CL 60 - R 502 - R 502 V.V. - R 602 - R 602 V.V.

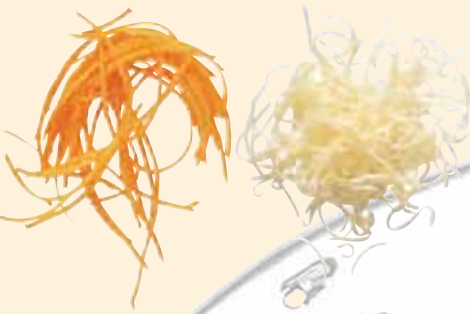
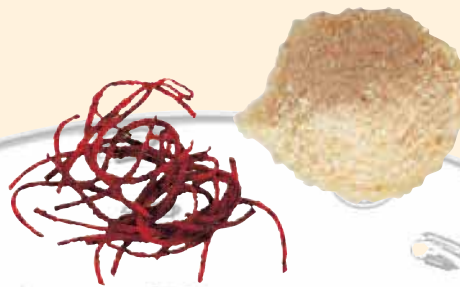
1,5 mm
Ref. : 28056

2 mm
Ref. : 28057

3 mm
Ref. : 28058

4 mm
Ref. : 28073

5 mm
Ref. : 28059

7 mm
Ref. : 28016

9 mm
Ref. : 28060

Parmesan
Ref. : 28061

Röstis
Ref. : 27164

Horseradish
1 mm
Ref. : 28055





The widest range of cuts

Dicing Equipments

CL 50 - CL 50 Ultra - CL 52 - CL 55 - CL 60 - R 502 - R 502 V.V. - R 602 - R 602 V.V.

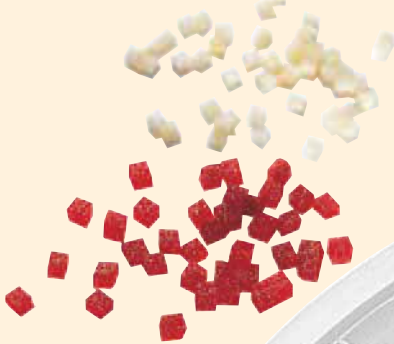

5x5x5 mm
Ref. : 28110



8x8x8 mm
Ref. : 28111

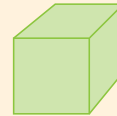
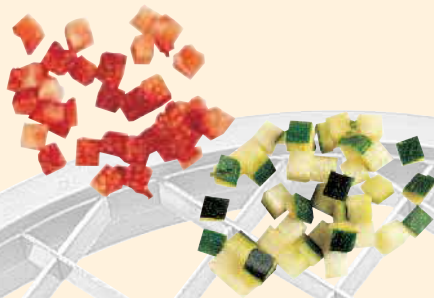

10x10x10 mm
Ref. : 28112



14x14x14 mm
Ref. : 28113

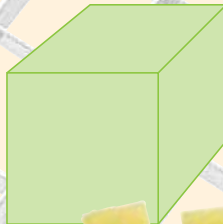

20x20x20 mm
Ref. : 28114

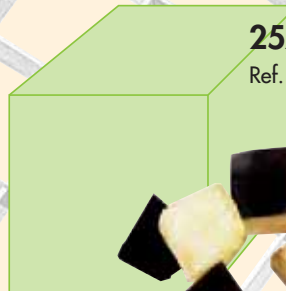

25x25x25 mm
Ref. : 28115

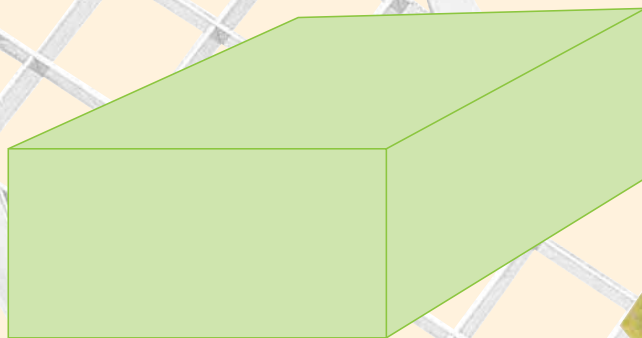

50x70x25 mm

Lettuce
Ref. : 28180



Ripple cuts

CL 50 - CL 50 Ultra - CL 52 - CL 55 - CL 60 - R 502 - R 502 V.V. - R 602 - R 602 V.V.



2 mm
Ref. : 27068



3 mm
Ref. : 27069



5 mm
Ref. : 27070



R 501 Ultra A, R 502, R 602, CL 50, CL 50 Gourmet, CL 52, CL 55, CL 60

EMINCEURS / SLICERS

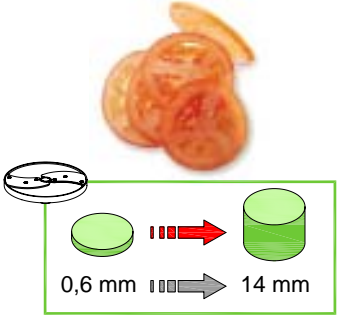
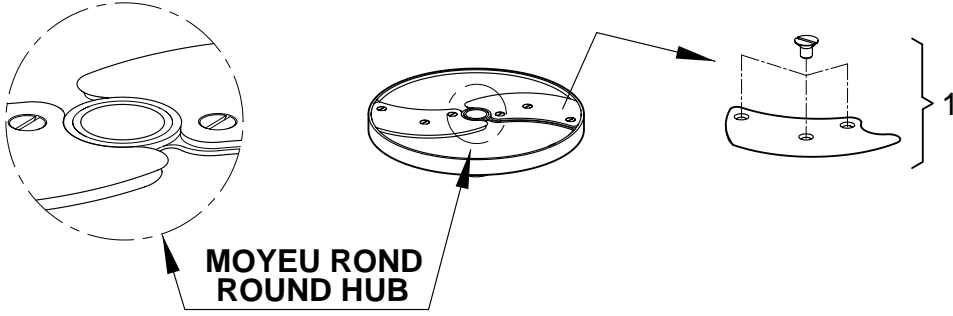
 <p>0,6 mm → 14 mm</p>	 <p>MOYEU ROND ROUND HUB</p>
<p>0,6 mm 0,8 mm 1 mm 2 mm 3 mm 4 mm 5 mm 8 mm 10 mm 14 mm</p>	<p>2* 3* 4* 5* 6* 7* 8* 9* 10* 11*</p>

EMINCEURS POMME DE TERRE / POTATOES SLICERS

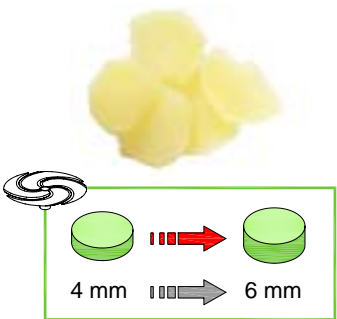
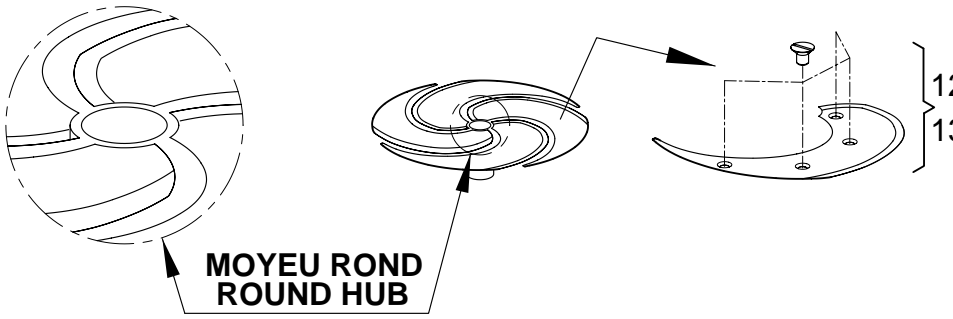
 <p>4 mm → 6 mm</p>	 <p>MOYEU ROND ROUND HUB</p>
<p>4 mm 6 mm</p>	<p>12* 13*</p>

ONDULÉS / WAVED CUT

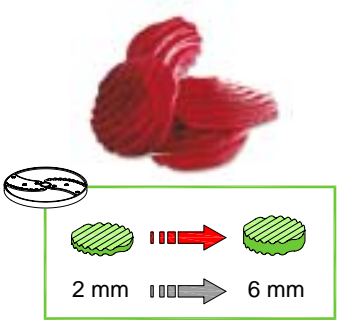
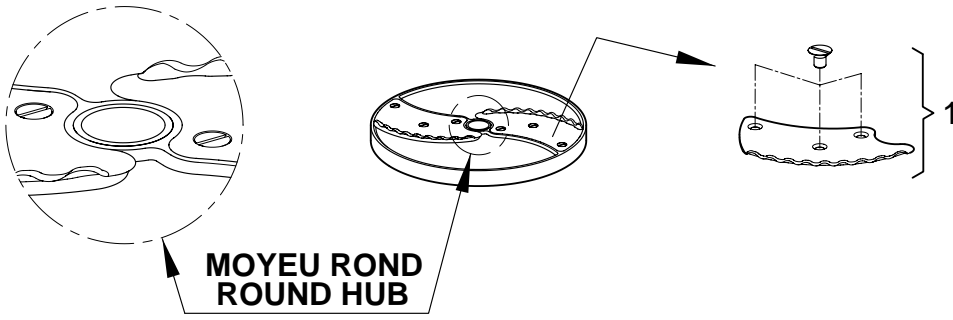
 <p>2 mm → 6 mm</p>	 <p>MOYEU ROND ROUND HUB</p>
<p>2 mm 4 mm 6 mm</p>	<p>14 15* 16* 17*</p>

Pos.	Part No	Description	Pos.	Part No	Description
001	29564	ENSEMBLE LAME/VIS DISQUE CL50			
002	28166	EMINCEUR 0,6			
003	28069	EMINCEUR 0,8			
004	28062	EMINCEUR 1			
005	28063	EMINCEUR 2			
006	28064	EMINCEUR 3			
007	28004	EMINCEUR 4			
008	28065	EMINCEUR 5			
009	28066	EMINCEUR 8			
010	28067	EMINCEUR 10			
011	28068	EMINCEUR 14			
012	27244	EMINCEUR 4			
013	27245	EMINCEUR 6			
014	29786	ENSEMBLE LAME ONDULEE + VIS			
015	27068	ONDULE 2			
016	27069	ONDULE 3			
017	27070	ONDULE 5			
012A	39723	LAME EMINCEUR 4 + VIS			
013A	39724	LAME EMINCEUR 6 + VIS			